

D1SC-N/D1SA Series

7-Segment Display Unit with High Bright Characters (D1SC-N: W32×H57mm, D1SA Series: W11×H22mm)

■ Features

- Selectable decimal (0 to 9) or hexadecimal (0 to 9, A to F) indication code
- Selectable positive or negative input logic
- Selectable serial or parallel data input method
- 7-segment, red/green display (D1SA Series)
- Power source: 12-24VDC
- Wide range on signal input voltage level (Low: Max. 0-1.2VDC, High: 4.5-24VDC)
- Easy multi-stages connection (D1SA Series)
- Zero Blanking function

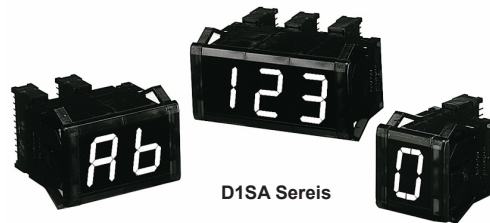

 Please read "Safety Considerations" in the instruction manual before using.

■ Specifications

Model	D1SC-N	D1SA-RN	D1SA-GN ^{※1}
Display method	7-segment LED display (red)		7-segment LED display (green)
Power supply	12-24VDC=		
Allowable voltage range	90 to 110% of rated voltage		
Current consumption	Max. 70mA	Max. 35mA	
Character size	W32×H57mm	W11×H22mm	
Display character ^{※2}	• Decimal number: 0 to 9, decimal point • Hexadecimal number: 0 to 9, A to F, decimal point		
Input	• Parallel: Parallel 4-bit data, latch, zero blanking, decimal point • Serial: Serial 4-bit or 5-bit data, clock, zero blanking, latch, decimal point (for 4-bit input)		
Input resistance	12kΩ	20kΩ	
Input level	High: 4.5-24VDC=, Low: 0-1.2VDC=		
Max. Clock	Max. 3kHz		
Output	Data output (serial input), zero blanking output		
Input logic	Selectable positive logic (PNP) or negative logic (NPN) (D1SC-N: by the function set switch, D1SA Series: by inner soldering)		
Noise immunity	±300V the square wave noise (pulse width: 1μs) by the noise simulator		
Environment	Ambient temperature	0 to 60°C, storage: -10 to 85°C	
	Ambient humidity	35 to 85%RH	
Accessory	Housing[5264-10], Terminal[5263 (PBT)], Sub-PCB for multi-stage connection	Connector (CT-10S), Cap	
Unit weight	Approx. 100g	Approx. 22g (including right/left caps)	

※1: It is option.

※2: Only D1SC-N supports Minus displaying.

※Max. Clock is for 1:1 of duty ratio (ON, OFF ratio).

※Environment resistance is rated at no freezing or condensation.

7-Segment Display Unit

Terminal Layout and Function

◎ D1SC-N

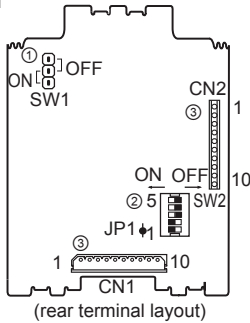

② Function set switches (SW2, JP1)

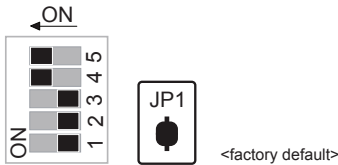

Switch	ON	OFF	Function	
SW2	1	Decimal	Hexadecimal	Characters
	2	Parallel	Serial	Input
	3	5-bit	4-bit	Serial input
	4	Used	Not used	Serial data output ^{※1}
	5	Used	Not used	Zero Blanking
JP1			Minus	
	7-segment	Minus		

※1: For Serial input, set this as ON.
For Parallel input, set this as OFF.

① Function set jumper (SW1)

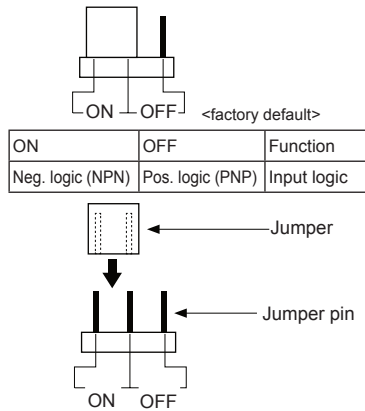

③ Input/Output terminals

Terminal	Parallel input		Serial input	
	Code	Function	Code	Function
1	V+	12-24VDC	VCC	12-24VDC
2	D0	Data input	N·C	Do not connect anything
3	D1		CK	Clock input
4	D2		DI	Data input
5	D3		DO	Data output
6	BI	Zero blanking input	BI	Zero blanking input
7	BO	Zero blanking output	BO	Zero blanking output
8	LE	Latch input	LE	Latch input
9	DP	Decimal point input	DP	Decimal point input
10	GND	0V	GND	0V

※Terminals of CN1 and CN2 is corresponding 1:1.

◎ D1SA Series

① Function set switches

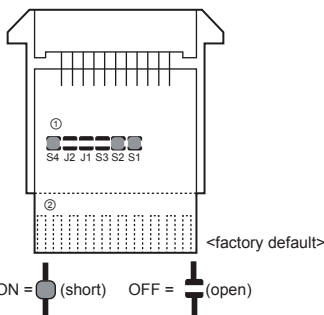

Switch	ON	OFF	Function
S1	Decimal	Hexadecimal	Characters
S2	Parallel	Serial	Input
S3	5-bit	4-bit	Serial input
J1	Used	Not used	Serial data output ^{※1}
J2	Used	Not used	Zero Blanking
S4	Neg. logic (NPN)	Pos. logic (PNP)	Input logic

※1: For serial input, set this as ON. For Parallel input, set this as OFF.

② Input/Output terminals

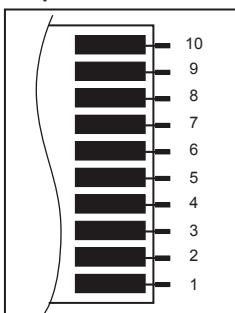

Terminal	Parallel input		Serial input	
	Code	Function	Code	Function
1	V+	12-24VDC	VCC	12-24VDC
2	D0	Data input	N·C	Do not connect any hing
3	D1		CK	Clock input
4	D2		DI	Data input
5	D3		DO	Data output
6	BI	Zero Blanking input	BI	Zero Blanking input
7	BO	Zero Blanking output	BO	Zero Blanking output
8	LE	LATCH input	LE	LATCH input
9	DP	Point input	DP	Point input
10	GND	0V	GND	0V

SENSORS

CONTROLLERS

MOTION DEVICES

SOFTWARE

(J) Temperature Controllers

(K) SSRs

(L) Power Controllers

(M) Counters

(N) Timers

(O) Digital Panel Meters

(P) Indicators

(Q) Converters

(R) Digital Display Units

(S) Sensor Controllers

(T) Switching Mode Power Supplies

(U) Recorders

(V) HMIs

(W) Panel PC

(X) Field Network Devices

D1SC-N/D1SA Series

Block Diagram

Parallel input

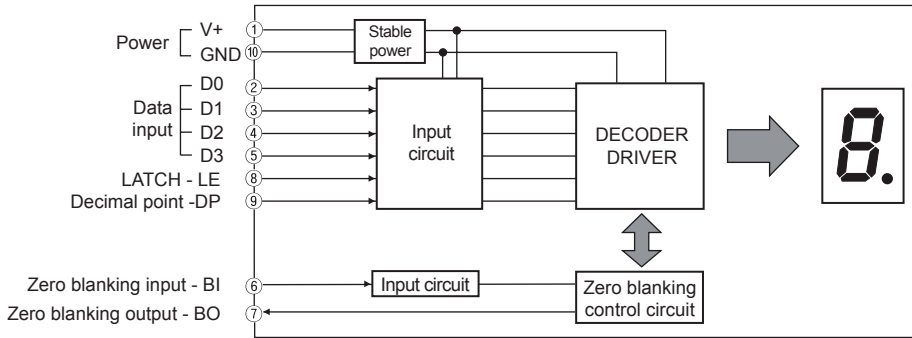

Serial input

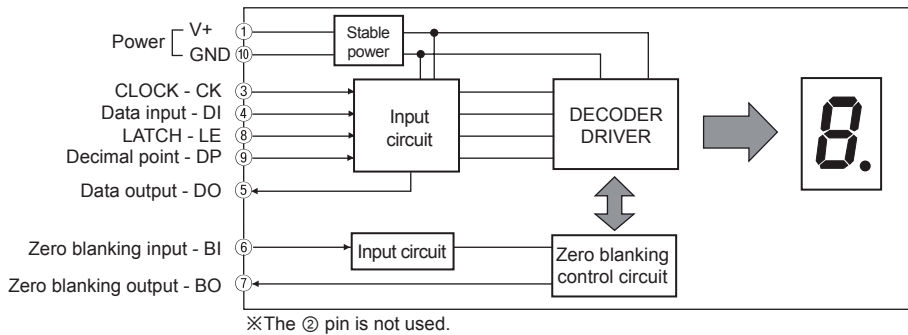

Dimensions

(unit: mm)

D1SC-N

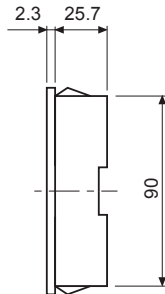
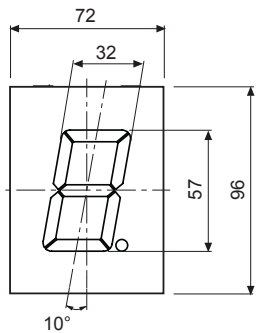

Panel cut-out

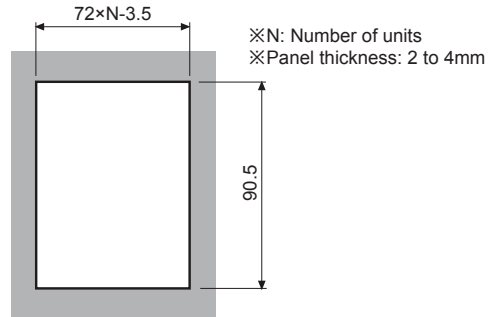

Accessories

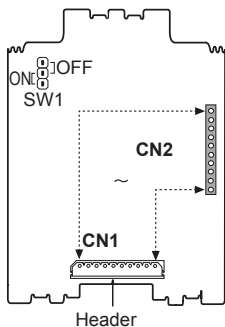

■ CN1: Connector specification

- Connector maker: Korea Morex
- Housing: 5264-10
- Header: 5264-10A (straight)
- Terminal: 5263 (PBT)
- Using cable specification
- AWG28 to 22 (cable diameter: Max. \varnothing 1.9mm)
- Shielding length of wire cover: 2.4 to 2.9mm

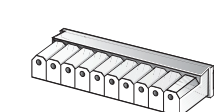

Housing[5264-10]

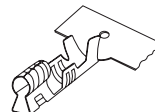

Terminal[5263 (PBT)]

■ CN2: Connector for multi-stage

- This connector must be used with connection PCB
- CN1 and CN2 must be connected as below drawing.

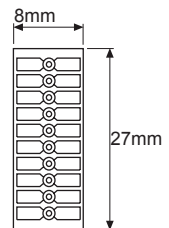

Multi-stage connector

7-Segment Display Unit

◎ D1SA Series

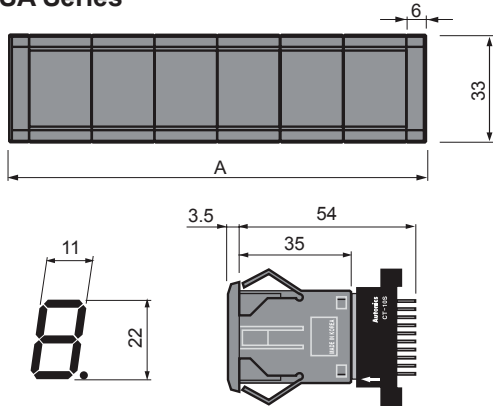

● Panel cut-out

(unit: mm)

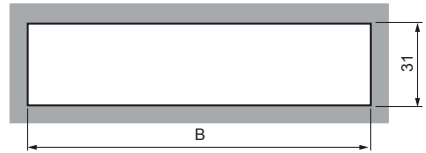

● Panel cut-out chart

Digit (N)	A (20×N+12)	B (20×N+10)
1	32	30±0.1
2	52	50±0.1
3	72	70±0.1
4	92	90±0.1
5	112	110±0.1
6	132	130±0.1
7	152	150±0.1
8	172	170±0.1

◎ Accessory

● Connector (model: CT-10S)

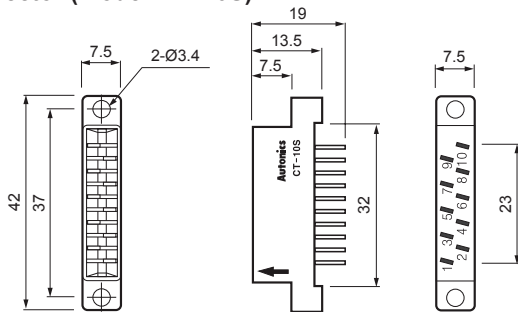

◎ Sold separately

● CAP



- D1SA-RN: DAR(L) -R (left/right 1 set)
- D1SA-GN: DAR(L) -BL (left/right 1 set)
- ※Cap is optional (1set).

■ Input Data Chart

Indication				Negative input				Positive input			
Minus ^{※1}		7-segment		D3	D2	D1	D0	D3	D2	D1	D0
Hexa decimal	Decimal	Hexa decimal	Decimal								
Blank	Blank	0	0	H	H	H	H	L	L	L	L
Blank	Blank	1	1	H	H	H	L	L	L	L	H
-	-	2	2	H	H	L	H	L	L	H	L
-	-	3	3	H	H	L	L	L	L	H	H
-	-	4	4	H	L	H	H	L	H	L	L
-	-	5	5	H	L	H	L	L	H	L	H
-	-	6	6	H	L	L	H	L	H	H	L
Blank	Blank	7	7	H	L	L	L	L	H	H	H
-	-	8	8	L	H	H	H	H	L	L	L
-	-	9	9	L	H	H	L	H	L	L	H
-	Blank	A	Blank	L	H	L	H	H	L	H	L
-	Blank	b	Blank	L	H	L	L	H	L	H	H
Blank	Blank	c	Blank	L	L	H	H	H	H	L	L
-	Blank	d	Blank	L	L	H	L	H	H	L	H
-	Blank	e	Blank	L	L	L	H	H	H	H	L
-	Blank	f	Blank	L	L	L	L	H	H	H	H

※When BI terminal connect GND, "0" is displayed. When BI terminal is open, it is blank (not display)

※"X": Either high or low level can be input.

※1: Only D1SC-N supports Minus display. Set the rear JP1 as OFF.

※Blank: If input signal as input DATA, it does not display.

SENSORS

CONTROLLERS

MOTION DEVICES

SOFTWARE

(J) Temperature Controllers

(K) SSRs

(L) Power Controllers

(M) Counters

(N) Timers

(O) Digital Panel Meters

(P) Indicators

(Q) Converters

(R) Digital Display Units

(S) Sensor Controllers

(T) Switching Mode Power Supplies

(U) Recorders

(V) HMIs

(W) Panel PC

(X) Field Network Devices

D1SC-N/D1SA Series

Input Circuit

D1SC-N

Positive logic (PNP) input (SW1: OFF)

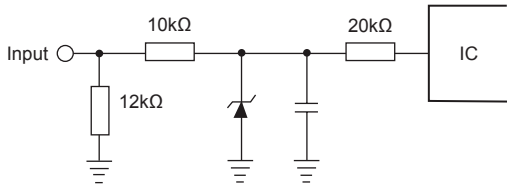

※Input level - High: 4.5-24VDC, Low: 0-1.2VDC

Negative logic (NPN) input (SW1: ON)

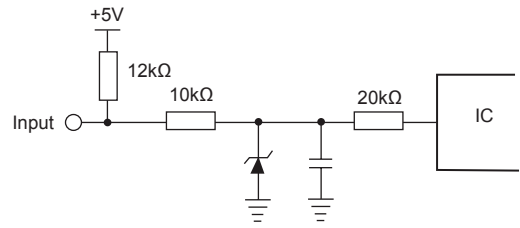

D1SA Series

Positive logic (PNP) input (SW1: OFF)

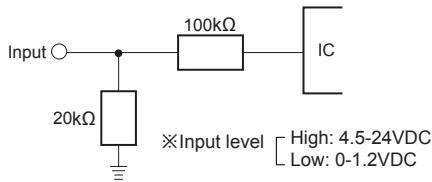

※Input level [High: 4.5-24VDC
Low: 0-1.2VDC

Negative logic (NPN) input (SW1: ON)

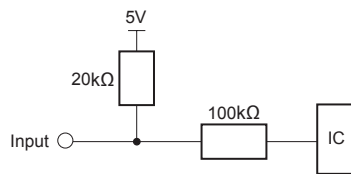

Data Input Method

Parallel input

4-bit static parallel input (e.g.: displays ABCD.)

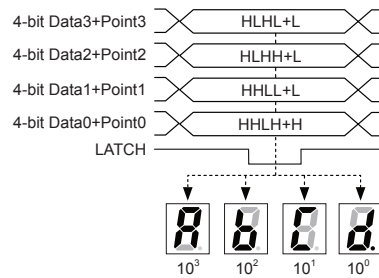
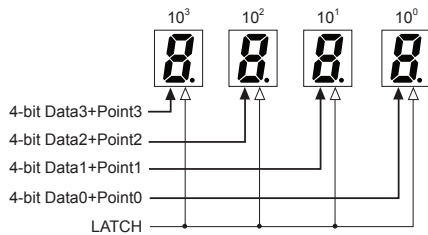

4-bit dynamic parallel input (e.g.: displays ACE007.)

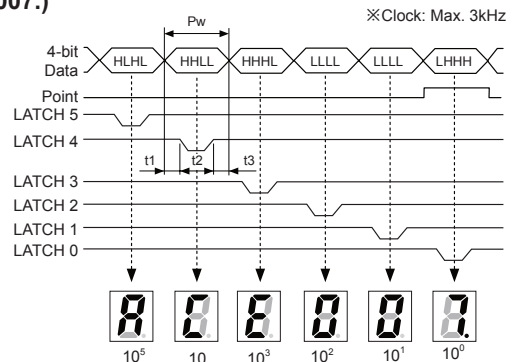
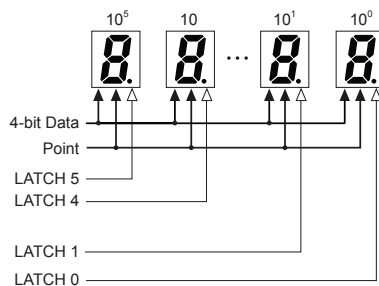

※Pw=t1+t2+t3
Pw: 0.33ms (Min.)
t1: 0.05ms (Min.) → Data LATCH
t2: 0.23ms (Min.) → Data move
t3: 0.05ms (Min.) → Data

7-Segment Display Unit

Serial Input

4-bit serial input (e.g.: displays -20.8)

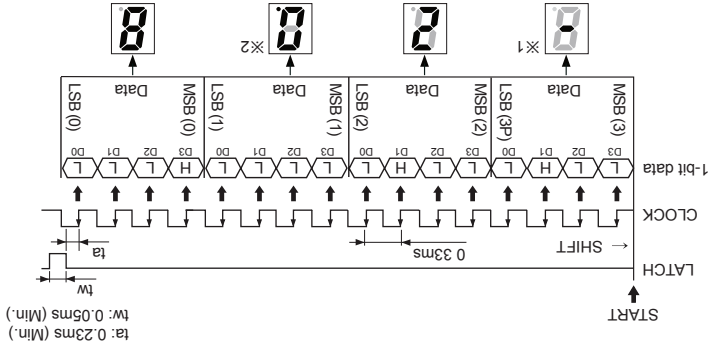

※Clock max. 3kHz
※In case of positive logic (PNP), hexadecimal number

5-bit serial input (e.g.: displays A25.0)

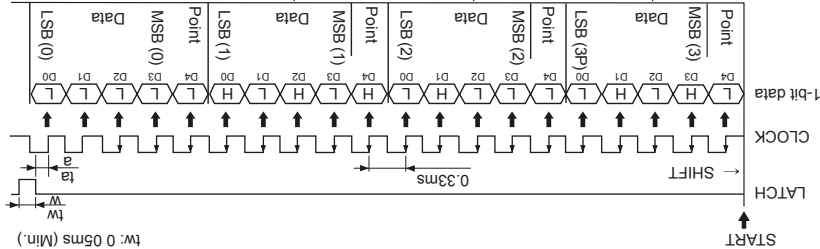

※1: To display Minus, set the rear JP1 as OFF.
※2: In case of 4-bit Serial input, to display decimal point, connect DP of the rear input terminal to V+.
In case of negative logic (NPN), connect DP to GND.

Multi-Stage Connection Method

※Do wiring after removing the rear case of the product.

Parallel input: 4-digit

※The below connection is example of D1SC-N. For D1SA, connection is same but the order of pin is reverse.
※CN1, CN2 terminals of D1SC-N corresponds 1:1 and it is able to connect as CN1 depending on the need.
※When not using Zero Blanking, connect BI terminal to GND.

Static parallel input (zero blanking method)

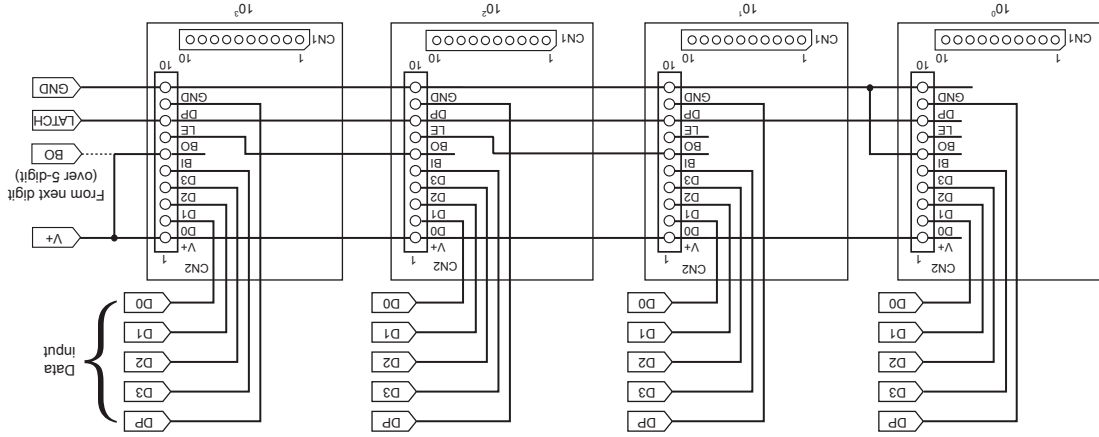

D1SC-N/D1SA Series

• Dynamic parallel input (zero blanking method)

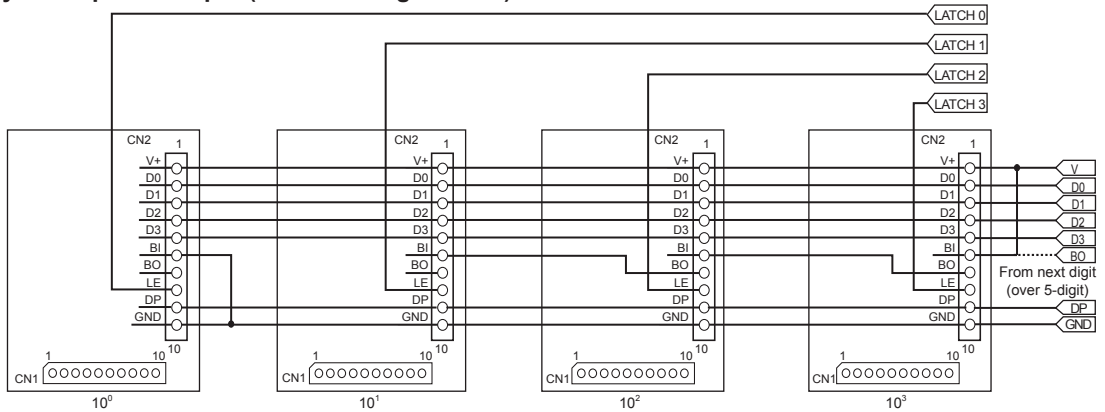

◎ Serial input: 4-digit

• Serial input (zero blanking method)

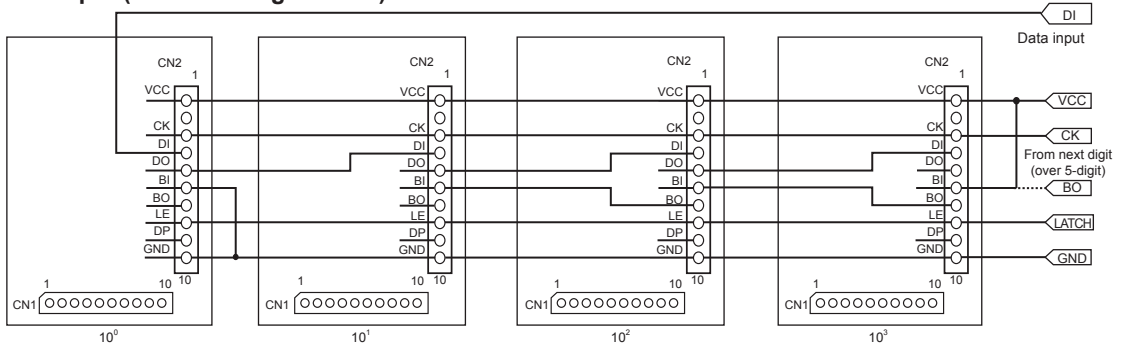

■ Zero Blanking Method?

It is to remove "0" indication which is no meaning.

E.g.1) When displaying 10

① Using Zero Blanking

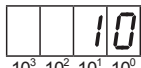

("0" of 10^3 , 10^2 are no meaning and they are not displayed.)

② Not using Zero Blanking

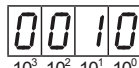

※If indication data is "101", meaningful tens place "0" will be displayed.

◎ Using zero blanking for multi-stage

Set 5 (zero blanking output) of the rear function set switch (SW2) as ON.

For 10 (0) to display '0', set this as OFF.

1) Using Zero Blanking

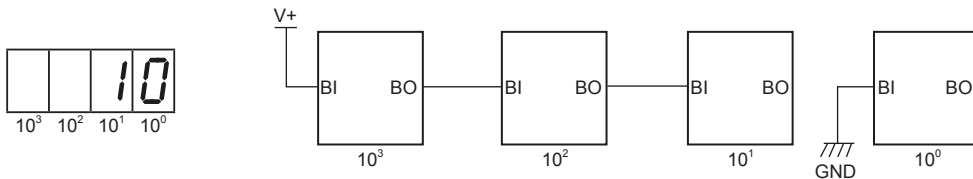

2) Not using Zero Blanking

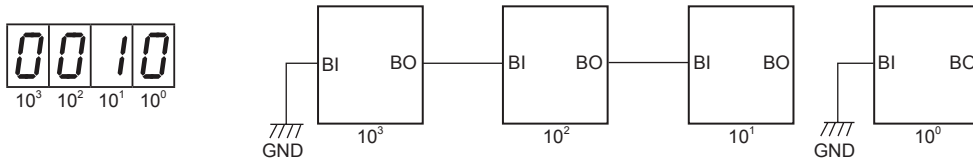

7-Segment Display Unit

■ The Application of PLC Program [Serial Input Type]

1. Display Unit D1SA-□
2. Data input type: Serial
3. Connection method: Refer to serial connection type when using more than 2.
4. Display result: "A" Display
5. PLC: LSI (LS Industrial Systems), MASTER-K Series
6. When using serial type, use transistor output card of PLC
7. Negative logic (NPN)

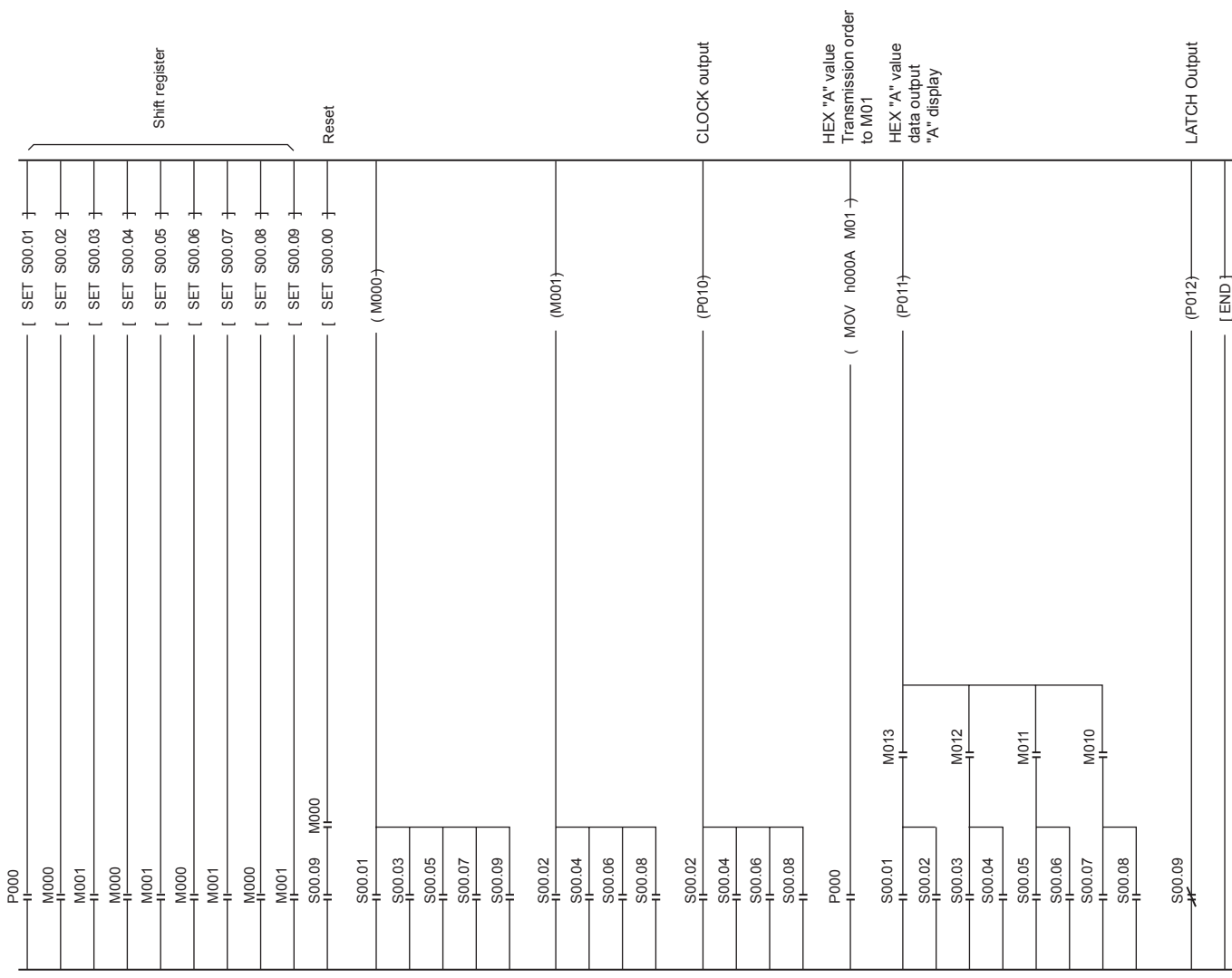

SENSORS
CONTROLLERS
MOTION DEVICES
SOFTWARE
(J) Temperature Controllers
(K) SSRs
(L) Power Controllers
(M) Counters
(N) Timers
(O) Digital Panel Meters
(P) Indicators
(Q) Converters
(R) Digital Display Units
(S) Sensor Controllers
(T) Switching Mode Power Supplies
(U) Recorders
(V) Hfills
(W) Panel PC
(X) Field Network Devices